

Hybrid Couplers are used in wireless distribution systems to combine two carrier signals without mutual interference or to split a signal into an RF path and an RF + DC path.

Base station antenna systems are increasingly being required to carry more than one carrier signal, to minimize environmental impact of additional antennas and associated new site legal costs. (These signals are often overlays such as the addition say of GSM to an existing TDMA system). See Figure 1.

Such systems require the splitting of the receive signal to feed each receive system independently. When tower top amplifiers are used a hybrid coupler becomes the preferred splitting device. The hybrid splits the signal equally, provides >30 dB of isolation and only passes the DC supply coming from one receiver. (The other DC supply may still need to be terminated, but that is another Microlab application note).

Note that for this application the fourth port of the hybrid is generally supplied with an internal termination. In this case the inherent passive intermodulation (PIM) of the hybrid is generally not a problem because the power levels are low.

Indoor distributed antenna systems Figure 2, often need to carry signals from two (or more) independent service providers. In this case, a hybrid coupler is used to combine the outputs from the two indoor micro base stations. Fortunately, minimal loss is incurred since in this application both outputs of the hybrid coupler may be used as feeds. Because the indoor antenna system is used for both transmit and receive paths, this system is more sensitive to PIM.

Coaxial signal distribution to antennas throughout the building can often be done without further amplification, provided Microlab's low loss reactive signal splitters and air-line couplers are used. Such systems have the great advantage of near perfect reliability.

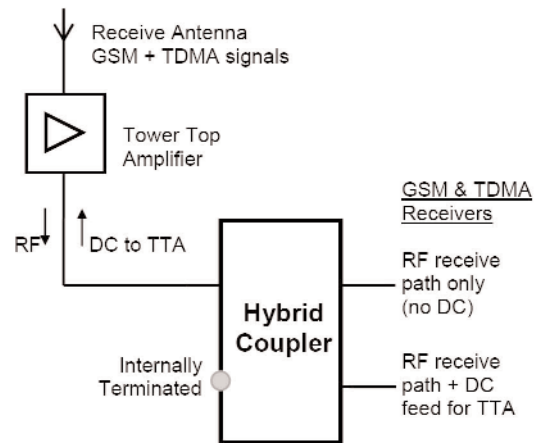

Figure 1. Co-Siting Receive Example

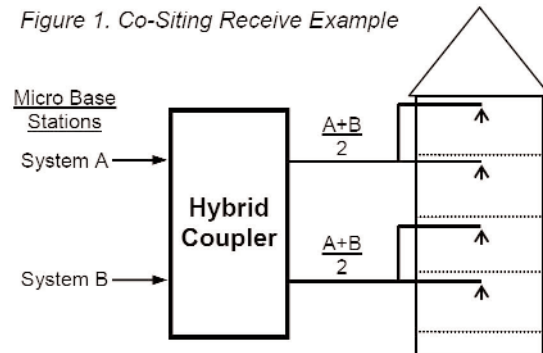

Figure 2. Typical In-Building System

#### DESIGN ALTERNATIVES

**Single or dual band coverage:** Dual band units permit the combination or division of signals from both the low and high bands. They cover all frequencies from 800 to 2,200 MHz. Single band units accept higher power and provide lower loss when compared with dual band units.

**Unterminated or internally terminated:** The fourth port of a low power coaxial hybrid can be terminated internally if the port is not utilized. Higher power hybrids are generally supplied unterminated.

**Selection of connectors:** N connectors are the most common choice for indoor wireless distribution systems; 7-16 mm DIN is preferred for the larger diameter cables used for long indoor runs and outdoor systems.

**Need for minimized passive intermodulation, PIM:** At higher power levels, a very low PIM is essential for all components. This is achieved through careful selection of metal and insulator materials and shapes, surface finishes, plating, and carefully controlled manufacturing processes.

#### MICROLAB HYBRID COUPLER ADVANTAGES

**Microlab is more familiar with all design alternatives:** Microlab offers superior specifications when compared with most other suppliers, including higher input isolation, lower loss and superior PIM performance. Other features include conveniently spaced connectors, simple mounting, and suitability for outside environments.

Microlab also offers a wide range of bandwidths as well as matrix models with 3 x 3 and 4 x 4 input/outputs.

**Product Adaptability:** Microlab is a flexible company, more capable of meeting rapid design changes to meet changing needs. For example, special hybrids may be supplied on request, with one port terminated internally, or with guaranteed ultra low PIM specifications.

**The Passive Specialist:** Microlab specializes in passive components, especially with low PIM. Unlike many of our competitors, our components are our main line of business.

Call or e-mail us your specific hybrid requirements.

