

Preliminary Data

- ◆ Interface of a LTE Tx/Rx port and Low Power Simplex of a DAS system
- ◆ Independently adjustable Tx and Rx levels
- ◆ Guaranteed Low PIM, High Isolation
- ◆ High Reliability, RoHS compliant
- ◆ Dual Standard 2RU Rack (3.5")



This Signal Conditioner Shelf, KM-55N, is designed to interface the two Tx/Rx signals of an LTE signal in the LTE-700 band, with a dual simplex DAS system. It allows independent level adjustment of the Tx and Rx elements of a wireless signal, when the signal is already split into Tx and Rx paths.

Because of the size and weight of the duplexers required the unit is split into two similar 2RU racks, differentiated only with the A and B designations. Each unit first duplexes the Tx/Rx inputs, and then attenuates the Tx signal by a fixed 6dB attenuator. It is then fed to a 0-30 dB level adjustment for optimum DAS performance. The interface is rated for input Tx powers of up to 60W/input. The DAS Rx signal is fed to a similar -30 dB level adjustment, and then to the duplexer. An optional 6 dB coupler in the receive path, provides an output to a location monitoring port if required. (09/11)

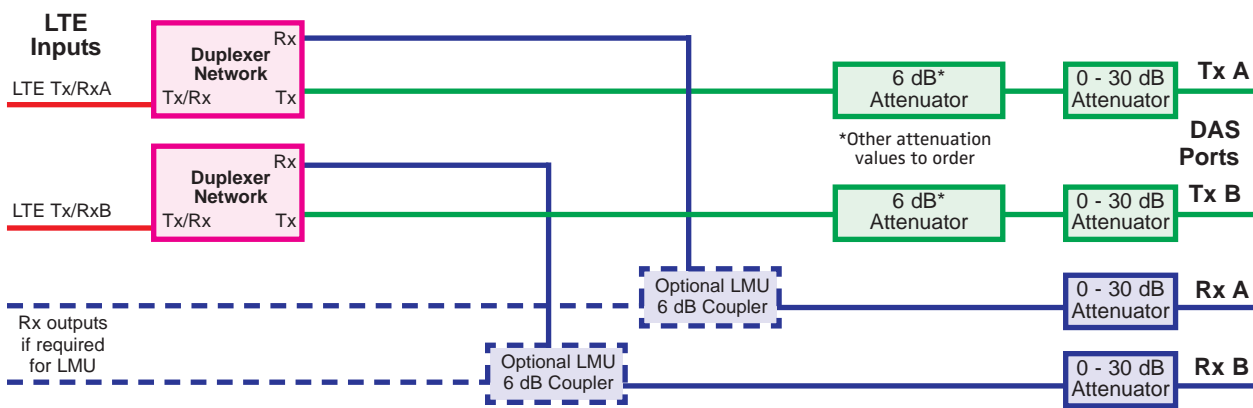

Frequency:	Two parts of an LTE B/C Block
Rx Band:	e.g. 704 - 716 MHz
Tx Band:	e.g. 734 - 746 MHz
Return Loss:	>19 dB, all ports
Tx Power/input:	60W avg max., 3 kW max pk.
Total Power In:	2W (requires no fixed pad) 8W (requires 6dB fixed pad) 20W (requires 10dB fixed pad) 50W (requires 15dB fixed pad) 200W (requires 20dB fixed pad)
Tx Path:	7 dB min. attenuation plus an adjustable 30 dB in 1 dB steps.
(with 6 dB pad)	
Rx Path:	2 dB min. attenuation plus an adjustable 30 dB in 1 dB steps.
Tx Isolation:	
Tx/Rx	To Rx: >60 dB
IMD, typical:	<-118 dBm in Rx band at input using two +43dBm tones
Impedance:	50Ω nominal
Environment:	0°C to +55°C, IP64
Housing:	Passivated aluminum
Connectors:	N(f), Triplate, SMA (f) gold
Weight:	25 lbs. nom. each 2RU rack
MTBF:	>500,000 hours

2 RU Rack Outline

